



Model No. 18.4B4R Series
Competition Light Set
Operating Instructions

Connect the lights, power supply and buzzer as shown below. Plug power supply into wall outlet and let games begin.

To add additional modules, just unplug the buzzer from the last module and plug in as many additional modules as required, then plug the buzzer into the last module.

If more space is desired between modules, simply connect a 48" extension between the two modules that can be connected together, if the buzzer is not required, simply disconnect.

Each Competition Light Set comes complete with a rugged carrying case and 4 individual cover sleeves. The bag is designed with many functional features ideal for transporting the Competition Light Kit from one academic event to another.

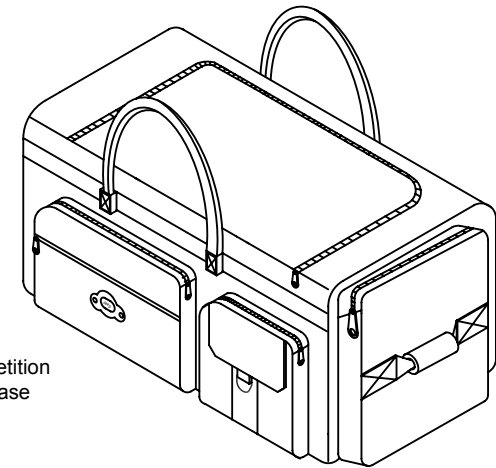

90.65096 Competition Light Carrying Case

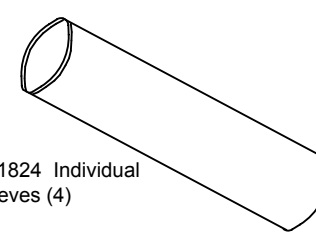

95.1824 Individual Sleeves (4)

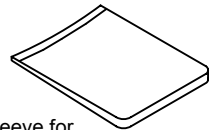

95.1830 Sleeve for Power Supply (1)

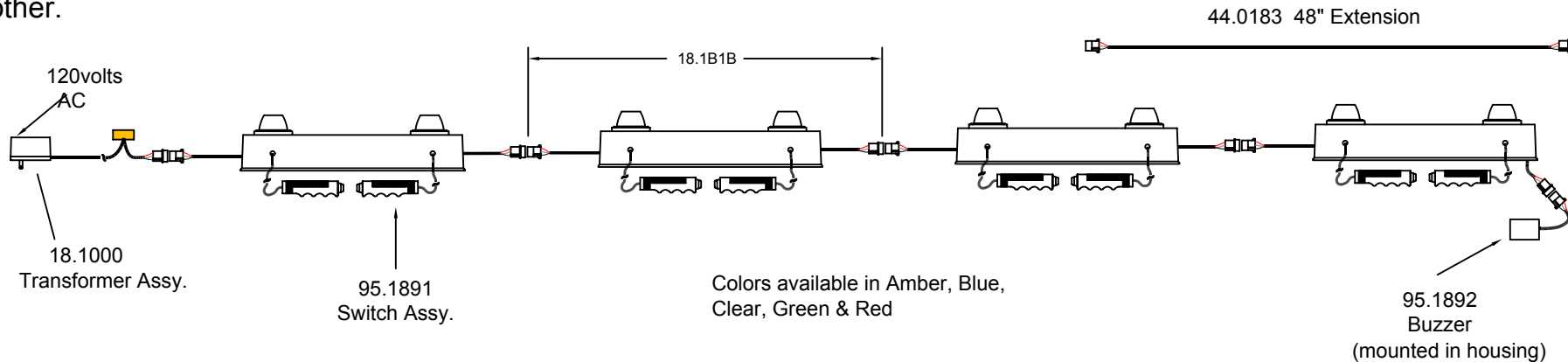

ALERTE SYSTEMS INC

901 W 10th Street / P.O. Box 586 / Cassville, MO 65625

Local & International Numbers:
Phone 417-846-2222 / Fax 417-846-2506

U.S. and Canada Toll-Free Numbers:
Phone 800-728-1536 / Fax 800-635-1536

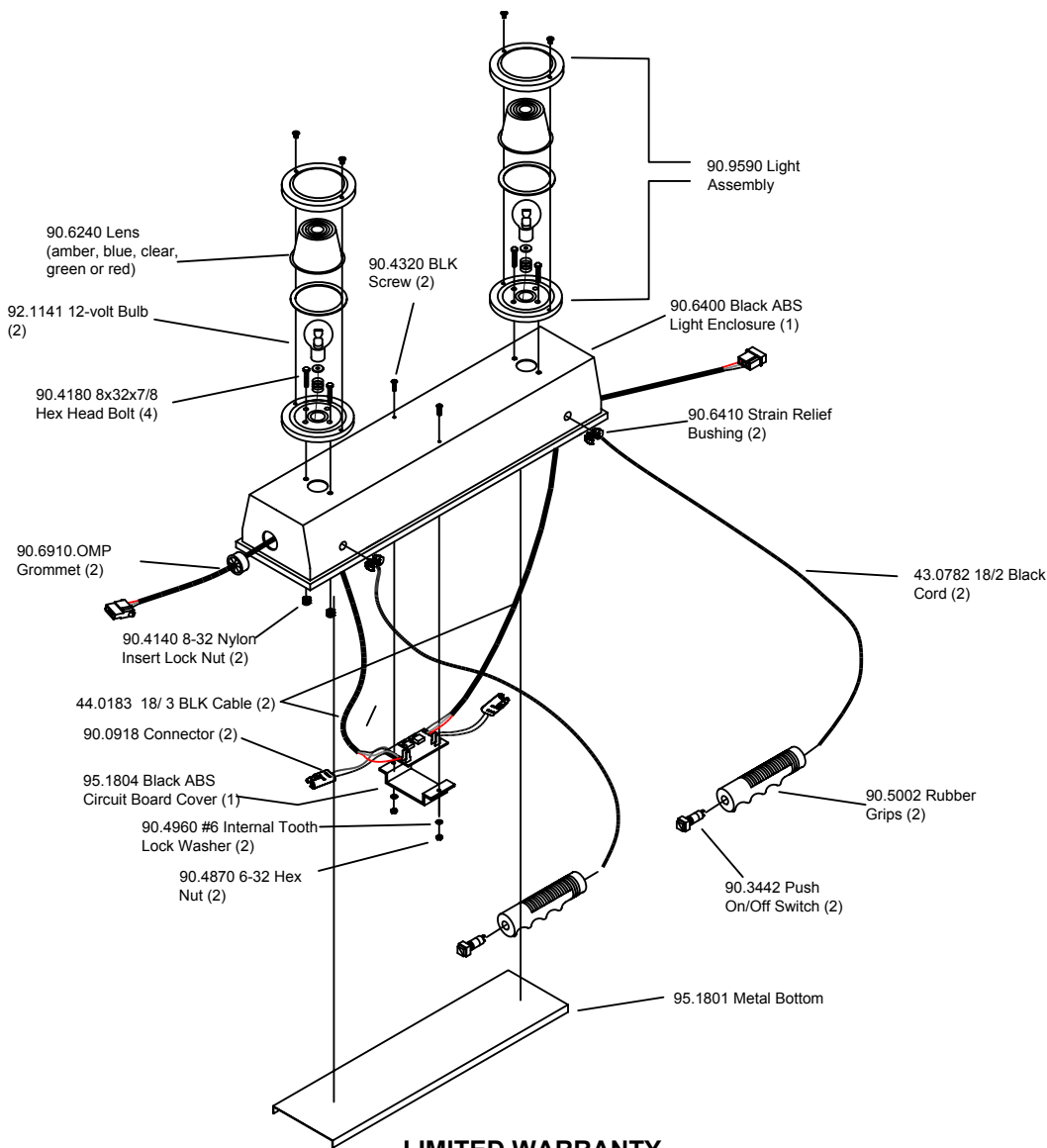

LIMITED WARRANTY

ALERTE warrants each new product (except bulbs, strobe power supplies and strobe tubes) to be free from defects in material and workmanship for a period of two years from the date of purchase. During this warranty period, the obligation of ALERTE is limited to repairing or replacing, as ALERTE may elect, any part or parts, which after examination by ALERTE are determined to be defective, when they are delivered pre-paid. This limited warranty does not cover travel expense, the cost of specialized equipment for gaining access to the product, or labor charges for the removal and re-installation of the product.

ALERTE shall not be liable for incidental or consequential damages, including but not limited to: loss of use of vehicle, rental of substitute vehicle, loss of time, loss of work, inconvenience, transportation expenses, telephone, lodging, loss of revenue, loss of and/ or damage to personal property for or arising out of breach of any express or implied warranty of its products.

Use of lamp or other electrical load of wattage higher than installed or recommended by the factory, or use of inappropriate or inadequate wiring or circuit protection causes this limited warranty to become void. ALERTE will in no way be liable for any loss of profits or any indirect or consequential damages arising out of any such defect in material and workmanship whether loss is due to negligence or breach of warranty. This limited warranty does not apply to shipping damage, accident, alteration, tampering, misuse or abuse and unauthorized service.

This limited warranty is expressly in lieu of all other express or implied warranties, including the implied warranty of merchant ability and the implied warranty of fitness for a particular purpose, and of all other obligation or liabilities on the part of ALERTE. There are no warranties, unless expressed in authorized ALERTE literature, which extend beyond the description of the face hereof. No dealer, distributor, employee, or representative of the company is authorized to change this warranty in any way or to grant any other warranty.

PRODUCT RETURNS

If a product must be returned, contact our factory by calling 1-800-728-1536 to obtain a Return Authorization Number (RA) before you ship the product. Write the RA number clearly on the package and return it to ALERTE Systems International, Ltd., 901 West 10th Street, P.O. Box 586, Cassville, MO 65625. A packing slip should be included with all shipments listing the sender's name, address, daytime phone number and description of defect. Your product will be put in first-class operating condition or replaced with a new part, and returned pre-paid.